

自行走剪叉式高空作业平台 Self-propelled scissor type aerial work platform

产品特性

1. 零转弯半径，可实现原地转向，可以在狭小的空间内灵活操作和作业。
2. 具有舒适宽大的防滑工作平台，和更长的延伸工作平台。
3. 标配完善的安全传感器和报警系统，工作频闪灯、防夹手预警，低电压报警。
4. 全新的电比例控制系统，具有故障自动诊断、故障代码显示和报警系统，更平稳更稳定。
5. 臂架和关键部件选用高强度钢和电泳处理，防腐性能提高三倍以上，突破10万次的疲劳测试。
6. 更可靠的主动式坑洼保护系统，提高了整车的安全性能和通过性能。
7. 零部件通用化、模块化设计，和两侧整体旋出式托盘，检修保养更便捷。
8. 应急下降系统、手动解刹系统和安全支撑臂，让维修更简单更高效。

Product Features

1. Zero turning radius, can realize in situ steering, can operate and work flexibly in a narrow space.
2. It has comfortable and wide non-slip working platform, and longer extended working platform.
3. Standard equipped with perfect safety sensor and alarm system, strobe light, anti-clamp alarm, low voltage alarm.
4. New electric proportional control system, with automatic fault diagnosis, fault code display and alarm system, more stable and more stable.
5. The boom and key components are selected for high-strength steel and electrophoresis treatment, which improves the anti-corrosion performance by more than three times and breaks through 100,000 fatigue tests.
6. More reliable active pothole protection system improves vehicle safety and passability.
7. Parts universal, modular design, and both sides of the whole rotary tray, maintenance is more convenient.
8. Emergency descent system, manual release brake system and safety support arm make maintenance more simple and efficient.



自行走剪叉式高空作业平台参数 Technical Data

特征 Characteristics									
1.01	型号 Model		JS0812	JS0812E	JS1012	JS1012E	JS1212	JS1212E	
尺寸 Dimensions									
2.01	最大工作高度 Max. working height	m	10	10	12	12	13.9	13.9	
2.02	最大平台高度 Max. platform height	m	8	8	10	10	11.9	11.9	
2.03	整机长度 Overall length	m	2.4	2.4	2.4	2.4	2.4	2.4	
2.04	整机宽度 Overall width	m	1.15	1.15	1.15	1.15	1.15	1.15	
2.05	整机高度(护栏未折叠) Overall height (guardrail unfolded)		2.3	2.3	2.46	2.46	2.60	2.60	
2.06	整机高度(护栏折叠) Overall height (guardrail folded)	m	1.71	1.71	1.84	1.84	1.98	1.98	
2.07	平台尺寸(长X宽F) Platform size (length x width)	m	2.29X1.15	2.29X1.15	2.29X1.15	2.29X1.15	2.29X1.15	2.29X1.15	
2.08	护栏高度 Guardrail height	m	1.1	1.1	1.1	1.1	1.1	1.1	
2.09	平台延伸尺寸 Extension size of platform	m	1	1	1	1	1	1	
2.10	离地间隙(收拢状态) Ground clearance (retracted state)	mm	95	95	95	95	95	95	
2.11	离地间隙(起升状态) Ground clearance (lifting state)	mm	20	20	20	20	20	20	
2.12	轴距 Wheelbase	m	1.85	1.85	1.85	1.85	1.85	1.85	
性能 Performance									
3.01	最大工作人数(室内/室外) Max. number of workers (indoor / outdoor)		2 / 1	2 / 1	2 / 1	2 / 1	2 / -	2 / -	
3.02	额定载荷 Rated capacity	kg	450	450	320	320	320	320	
3.03	延伸平台额定载荷 Rated capacity of extension platform	kg	120	120	120	120	120	120	
3.04	行驶速度(收拢状态) Drive speed (retracted state)	km/h	0~3.2	0~3.2	0~3.2	0~3.2	0~3.2	0~3.2	
3.05	行驶速度(起升状态) Drive speed (lifting state)	km/h	0~0.8	0~0.8	0~0.8	0~0.8	0~0.8	0~0.8	
3.06	最小转弯半径(内侧) Min. turning radius (inside)	m	0	0	0	0	0	0	
3.07	最小转弯半径(外侧) Min. turning radius (outside)	m	2.2	2.2	2.2	2.2	2.2	2.2	
3.08	上升/下降时间 Lifting / Falling time	s	32/35	32/35	52/48	52/48	52/52	52/52	
3.09	最大允许倾斜角度(前后/左右) Max. allowable tilt angle (forward and backward / left and right)	°	3°/1.5°	3°/1.5°	3°/1.5°	3°/1.5°	3°/1.5°	3°/1.5°	
3.10	最大允许风速(室内/室外) Max. allowable wind speed (indoor / outdoor)	m/s	0/12.5	0/12.5	0/12.5	0/12.5	0/0	0/0	
3.11	最大允许侧向力(室内/室外) Max. allowable lateral force (indoor / outdoor)	N	400/200	400/200	400/200	400/200	400/0	400/0	
3.12	爬坡能力 Gradeability	%	30%	30%	25%	30%	25%	30%	
3.13	控制类型 Control type		比例控制 Proportional control						
3.14	驱动 Drive		双前轮 Dual front wheels						
3.15	制动 Brake		双后轮 Dual rear wheels						
3.16	轮胎规格 Tyre size	mm	381X129	381X129	381X129	381X129	381X129	381X129	
电机 Drive									
4.01	起升/驱动电机功率 Lifting / driving motor power	kw	3.3	3.3/0.7X2	3.3	3.3/0.7X2	4.5	3.3/0.7X2	
4.02	电池电压/容量 Battery voltage / capacity	V/Ah	6X4/225	6X4/225	6X4/225	6X4/225	6X4/300	6X4/300	
4.03	充电器输入电压 Charger input voltage	VAC	100-240	100-240	100-240	100-240	100-240	100-240	
4.04	充电器输出电流 Charger output current	A	36	36	36	36	36	36	
4.05	控制电压 Control voltage	VDC	24	24	24	24	24	24	
其它 Other									
5.01	整机重量 Overall weight	kg	2460	2460	2820	2820	2950	2950	

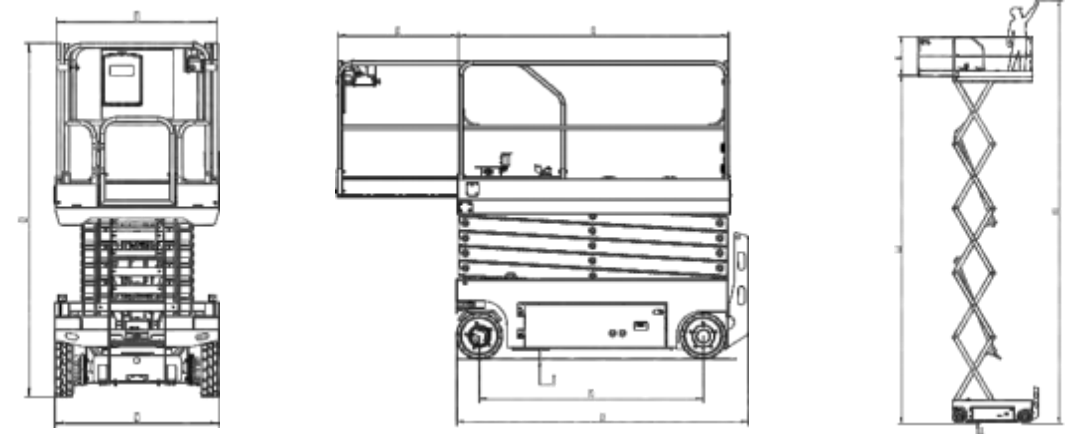

自行走剪叉式高空作业平台 Self-propelled scissor type aerial work platform

产品特性

- 1.零转弯半径，可实现原地转向，可以在狭小的空间内灵活操作和作业。
- 2.具有舒适宽大的防滑工作平台，和更长的延伸工作平台
- 3.标配完善的安全传感器和报警系统，工作频闪灯、防夹手预警，低电压报警。
- 4.全新的电比例控制系统，具有故障自动诊断、故障代码显示和报警系统，更平稳更稳定。
- 5.臂架和关键部件选用高强度钢和电泳处理，防腐性能提高三倍以上，突破10万次的疲劳测试。
- 6.更可靠的主动式坑洼保护系统，提高了整车的性能和安全性能。
- 7.零部件通用化、模块化设计，和两侧整体旋出式托盘，检修保养更便捷。
- 8.应急下降系统、手动解刹系统和安全支撑臂，让维修更简单更高效。

Product Features

- 1.Zero turning radius, can realize in situ steering, can operate and work flexibly in a narrow space.
- 2.It has comfortable and wide non-slip working platform, and longer extended working platform.
- 3.Standard equipped with perfect safety sensor and alarm system, strobe light, anti-clamp alarm, low voltage alarm.
- 4.New electric proportional control system, with automatic fault diagnosis, fault code display and alarm system, more stable and more stable.
- 5.The boom and key components are selected for high-strength steel and electrophoresis treatment, which improves the anti-corrosion performance by more than three times and breaks through 100,000 fatigue tests.
- 6.More reliable active pothole protection system improves vehicle safety and passability.
- 7.Parts universal, modular design, and both sides of the whole rotary tray, maintenance is more convenient.
- 8.Emergency descent system, manual release brake system and safety support arm make maintenance more simple and efficient.



自行走剪叉式高空作业平台参数 Technical Data

特征 Characteristics						
1.01	型号 Model		JS0607	JS0607E	JS0607W	JS0607WE
尺寸 Dimensions						
2.01	最大工作高度 Max. working height	m	7.8	7.8	7.8	7.8
2.02	最大平台高度 Max. platform height	m	5.8	5.8	5.8	5.8
2.03	整机长度 Overall length	m	1.84	1.84	1.84	1.84
2.04	整机宽度 Overall width	m	0.76	0.76	0.81	0.81
2.05	整机高度(护栏未折叠) Overall height (guardrail unfolded)	m	2.7	2.7	2.7	2.7
2.06	整机高度(护栏折叠) Overall height (guardrail folded)	m	2.1	2.1	2.1	2.1
2.07	平台尺寸(长EX宽F) Platform size (length x width)	m	1.84X0.76	1.84x0.76	1.84X0.76	1.84X0.76
2.08	护栏高度 Guardrail height	m	1.1	1.1	1.1	1.1
2.09	平台延伸尺寸 Extension size of platform	m	0.9	0.9	0.9	0.9
2.10	离地间隙(收拢状态) Ground clearance (retracted state)	mm	60	60	60	60
2.11	离地间隙(起升状态) Ground clearance (lifting state)	mm	15	15	15	15
2.12	轴距 Wheelbase	m	1.36	1.36	1.36	1.36
性能 Performance						
3.01	最大工作人数(室内/室外) Max. number of workers (indoor / outdoor)		2/ -	2/ -	2/ -	2/ -
3.02	额定载荷 Rated capacity	kg	230	230	230	230
3.03	延伸平台额定载荷 Rated capacity of extension platform	kg	120	120	120	120
3.04	行驶速度(收拢状态) Drive speed (retracted state)	km/h	0~4	0~4	0~4	0~4
3.05	行驶速度(起升状态) Drive speed (lifting state)	km/h	0~0.8	0~0.8	0~0.8	0~0.8
3.06	最小转弯半径(内侧) Min. turning radius (inside)	m	0	0	0	0
3.07	最小转弯半径(外侧) Min. turning radius (outside)	m	1.55	1.55	1.55	1.55
3.08	上升/下降时间 Lifting /Falling time	s	18/28	18/28	18/28	18/28
3.09	最大允许倾斜角度(前后/左右) Max. allowable tilt angle (forward and backward / left and right)	°	3°/1.5°	3°/1.5°	3°/1.5°	3°/1.5°
3.10	最大允许风速(室内/室外) Max. allowable wind speed (indoor / outdoor)	m/s	0/0	0/0	0/125	0/125
3.11	最大允许侧向力(室内/室外) Max. allowable lateral force (indoor / outdoor)	N	400/0	400/0	400/0	400/0
3.12	爬坡能力 Gradeability	%	25	30	25	30
3.13	控制类型 Control type		比例控制PROPORTIONAL CONTROL			
3.14	驱动 Drive		双前轮DUAL FRONT WHEELS			
3.15	制动 Brake		双后轮DUALREAR WHEELS			
3.16	轮胎规格 Tyre size	mm	323*100	323*100	323*100	323*100
电机 Drive						
4.01	起升/驱动电机功率 Lifting / driving motor power	kw	3.3	2.2/0.7x2	3.3	2.2/0.7x2
4.02	电池电压/容量 Battery voltage / capacity	V/Ah	6X4/225	6x4/225	6X4/225	6X4/225
4.03	充电器输入电压 Charger input voltage	VAC	100-240	100-240	100-240	100-240
4.04	充电器输出电流 Charger output current	A	36	36	36	36
4.05	控制电压 Control voltage	VDC	24	24	24	24
其它 Other						
5.01	整机重量 Overall weight	kg	1480	1480	1500	1500

